

**EXPERIMENTAL EVALUATION OF A CASCADE REFRIGERATION SYSTEM USING R-134a AND R-404a****ANÁLISE EXPERIMENTAL DA PERFORMANCE DE UM SISTEMA DE REFRIGERAÇÃO EM CASCATA UTILIZANDO COMO FLUIDOS R-134a E R-404a**Vitor Pinheiro Ferreira¹, Micael Lima Conceição², William Souza dos Santos³

e321127

<https://doi.org/10.47820/recima21.v3i2.1127>**ABSTRACT**

Cascade refrigeration system is an attractive technology for low-temperature requirement, allowing operation under these conditions with positive suction pressures and a moderate condensation pressure at ambient temperature. This work describes a performance analysis of a cascade refrigeration prototype equipped with hermetic compressors working with R-134a and R-404a as refrigerants, thermally connected by a tube-in-tube-type cascade-condenser. Energy flows and performance parameters were evaluated under different evaporating temperature conditions of the low temperature cycle (LTC). The results showed an increase in energy efficiency ratio (EER) and coefficients of performance (COP) of cascade system as well as of each cycle with the increase of LTC evaporating temperature, even with a simultaneous increase of temperature difference in cascade-condenser.

KEYWORDS: Refrigeration. Cascade refrigeration system. Energy analysis**RESUMO**

O ciclo de refrigeração em cascata é uma alternativa atraente para aplicações em extrabaixa temperatura de evaporação, permitindo a operação nestas condições com pressões de sucção adequadas. Este trabalho descreve uma análise de performance experimental em um ciclo de refrigeração cascata dotado de compressores herméticos que opera com os fluidos R-134a e R-404a conectados termicamente por um condensador-cascata do tipo tube in tube. Foram avaliados fluxos de energia e parâmetros de performance sob diversas condições de temperatura de evaporação do ciclo LTC. Os resultados apontam aumento de EER e coeficientes de performance do ciclo cascata, bem como de cada um dos ciclos individualmente com o aumento da temperatura de evaporação do ciclo LTC, mesmo com correspondente aumento do diferencial de temperatura no condensador-cascata.

PALAVRAS-CHAVE: Refrigeração. Sistema cascata. Análise energética**INTRODUCTION**

Refrigeration systems are very important in many commercial and industrial applications as well as human life. For this purpose, single-stage vapor compression refrigeration cycles are used in several applications such as air conditioning, food preservation and transportation (PAN et al., 2020). However,

¹ Engenheiro Mecânico com atuação na área de refrigeração e climatização, energia, petróleo e gás, biocombustíveis, motores de combustão interna, mestre em Mecatrônica e doutor em Energia. Professor do Instituto de Ciência, Tecnologia e Inovação da Universidade Federal da Bahia.

² Bacharel em Ciências Exatas e Tecnológicas, Engenheiro Mecânico pela Universidade Federal do Recôncavo da Bahia. Atuante na área de Refrigeração por mais de 5 anos.

³ Técnico em Eletromecânica pelo CETEB, Engenheiro Mecânico, Bacharel Ciências Exatas e Tecnológicas, Engenheiro Mecânico pela Universidade Federal do Recôncavo da Bahia, pós-graduando em Engenharia de climatização pela Faculdade Profissional (FAPRO).



RECIMA21 - REVISTA CIENTÍFICA MULTIDISCIPLINAR ISSN 2675-6218

EXPERIMENTAL EVALUATION OF A CASCADE REFRIGERATION SYSTEM USING R-134a AND R-404a
Vitor Pinheiro Ferreira, Micael Lima Conceição, William Souza dos Santos

under evaporating temperature below $-35\text{ }^{\circ}\text{C}$ single-stage systems working with traditional refrigerants are insufficient, showing negative suction pressure which could allow well marked oil drag through the discharge pipe and lead to air leakage into the system (DOPAZO; FERNANDEZ-SEARA, 2011). Also, with the increase of compression ratio, compressor volumetric efficiency and COP will be drastically reduced (ALHAMID et al., 2010). At such conditions, cascade refrigeration systems is a convenient option, allowing refrigeration in conditions of very-low evaporating temperature as in cryopreservation, rapid freezing and natural gas liquefaction applications (YOON et al., 2013).

Cascade refrigeration system is designed by connection of two or more refrigeration cycles, making it possible to reach evaporating temperatures up to $-170\text{ }^{\circ}\text{C}$ (PAN et al., 2020). The two-stage cascade system is the most common configuration consisting of two cycles, called high temperature cycle (HTC) and low temperature cycle (LTC), connected to each other by a heat exchanger called as cascade-condenser, which is simultaneously LTC condenser and HTC evaporator. Thus, better refrigeration capacity and higher COP is possible, if compared to traditional single-cycle systems.

Researches have proven the effectiveness of cascade refrigeration system in low-temperature conditions (BINGMING et al., 2009; DOPAZO; FERNANDEZ-SEARA, 2011; PAREKH; TAILOR, 2011). Messineo (2012) analyzed a cascade refrigeration system using thermodynamic methods. Results were compared to a double-stage system using R-404a. The results showed better performance for cascade system in a range of -30 to $-50\text{ }^{\circ}\text{C}$. Silva et al., (2009) compared a cascade system with two configurations traditionally applied to supermarkets using direct expansion of R-404a or R-22. The authors conducted the analysis on semi-hermetic compressor racks connected to cold rooms and displays at similar conditions verified in commercial refrigeration. They found that the cascade system showed lower annual energy consumption, lower refrigerant charge and lower global warming potential (GWP) than others configurations.

Refrigerants with high critical point and positive evaporating pressure under low-temperature conditions can be used in the cascade LTC (SUN et al., 2016; DU et al., 2009; KILICARSLAN; HOSOZO, 2010). However, factors such as toxicity, flammability, interaction with metals and lubricant and environmental impact must be taken into account when refrigerant selecting.

Several fluids have been used in the past, such as CFC refrigerants (R-13 and R-502) for the cascade LTC, and because they have a high ozone depletion potential (ODP), they were replaced by HFCs, which have a high GWP. Thus, new environmentally friendly fluids such as R-717 (NH_3), R-744 (CO_2) and hydrocarbons have been proposed. CO_2 is non-toxic, non-combustible, odorless and has very low GWP. Furthermore, it shows positive pressure even under extremely low-evaporating conditions, and therefore has been applied in cascade LTC. However, CO_2 shows high operating pressure which may characterize potential damage in commercial applications. Ammonia (R-717), a low-cost natural fluid with ODP and GWP equal to zero is often applied in cascade HTC. However, it is flammable and very toxic (LEE et al., 2006).



RECIMA21 - REVISTA CIENTÍFICA MULTIDISCIPLINAR ISSN 2675-6218

EXPERIMENTAL EVALUATION OF A CASCADE REFRIGERATION SYSTEM USING R-134a AND R-404a
Vitor Pinheiro Ferreira, Micael Lima Conceição, William Souza dos Santos

Many researches have been conducted about cascade refrigeration systems operating with CO₂ as LTC refrigerant (BELLOS; TZIVANID, 2019; MUMANACHIT et al., 2012; ALHAMID et al., 2010). Getu and Bansal (2008) performed a thermodynamic analysis in a cascade system with CO₂ (R-744) and NH₃ (R-717) to optimize operating conditions. They performed a linear regression to obtain a mathematical expression and found suitable values for evaporating temperature. The results showed that simultaneous increase in subcooling of two cycles provided an increase in global COP. The increase in condensing temperature as well as the reduction in evaporating temperature led to a reduction in COP. Similar results were also obtained by Lee et al., (2006). DOPAZO et al., (2009) performed a theoretical analysis on a cascade system model operating at low temperature with NH₃ and CO₂. The authors proposed an optimal value for CO₂ condensing temperature in order to maximize COP and exergetic efficiency. The results showed that COP increased 70% when CO₂ evaporating temperature ranged from -55 °C to -30 °C and decreased when ammonia condensing temperature increased from 25 °C to 50 °C. Dokandari et al., (2014) carried out an analysis based on the First and Second Laws of Thermodynamics evaluating use of an ejector in each cycle as an expansion device of a cascade system using CO₂ and NH₃ as refrigerants. The destruction of exergy decreased between 5 and 7% compared to traditional cycle with expansion valve.

Colorado and Rivera (2015) performed a theoretical analysis to compare the performance of a new compression-absorption double stage system to a classic single-stage system. The system consisted of a cascade LTC composed by a CO₂ compression cycle and a cascade HCT composed by a double-stage H₂O/LiBr absorption cycle, which absorbs the heat of condensation from the compression cycle. Energy consumption was about 45% lower than found in single-stage system using R134a as refrigerants under the same conditions.

The literature review shows several researches about performance simulation of cascade refrigeration systems using CO₂ and NH₃ as refrigerants. However, few experimental analysis are found. This work presents results about experimental analysis of a cascade refrigeration system working with refrigerants with lower toxicity and flammability than ammonia and with lower precautions about pressure risks that CO₂ installations require. Thus, the system can be applied in small refrigeration applications if low evaporating temperature is required.

MATERIALS AND METHODS

Experimental Prototype

A small refrigeration prototype was specially designed and built to evaluate the performance of cascade system operating at different refrigerants. The system is composed of two cycles (HTC and LTC) thermally interconnected by a cascade-condenser, as shown in Figure 1. In this work, performance data were analyzed using R-134a as refrigerant in the HTC and R-404a as LTC refrigerant.

RECIMA21 - REVISTA CIENTÍFICA MULTIDISCIPLINAR
ISSN 2675-6218

EXPERIMENTAL EVALUATION OF A CASCADE REFRIGERATION SYSTEM USING R-134a AND R-404a
 Vitor Pinheiro Ferreira, Micael Lima Conceição, William Souza dos Santos

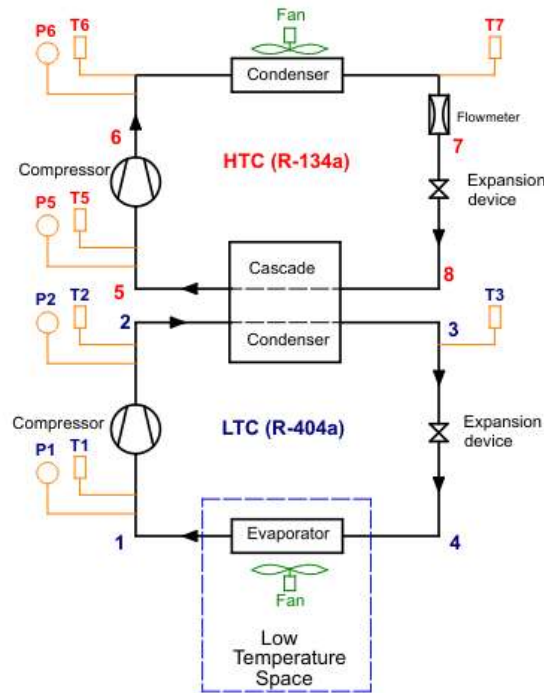

Figure 1. Schematic diagram of the cascade refrigeration prototype.

The system is equipped with a tube-in-tube-type cascade-condenser designed to provide a log-average temperature difference (LMTD) of 6°C between fluids at a LTC evaporating temperature of -40°C. The HTC condenser and the LTC evaporator are forced convection air cooled heat exchangers. Hermetic compressors were used in each cycle. The main characteristics of the employed compressors are shown in Table 1. The LTC compressor was originally applied for R-12. Thus, the original lubricant oil was replaced by polyol ester oil, suitable for R-404a applications.

For each cycle, pressure gauges (resolution of 7 kPa) and temperature measuring points were installed at the compressor suction and discharge. In addition, condensing pipe temperatures were also measured. Figure 2 shows the assembly details.

Table 1. Main characteristics of the HTC and LTC compressors.

Characteristics	LTC Compressor	HTC Compressor
Manufacturer	Embraco	Embraco
Model	PW-4.5	EMMIS-70HHR
Power (W)	95	150
Refrigerant	R-12	R-134-a
Voltage (V)	127	127
Frequency (Hz)	60	60

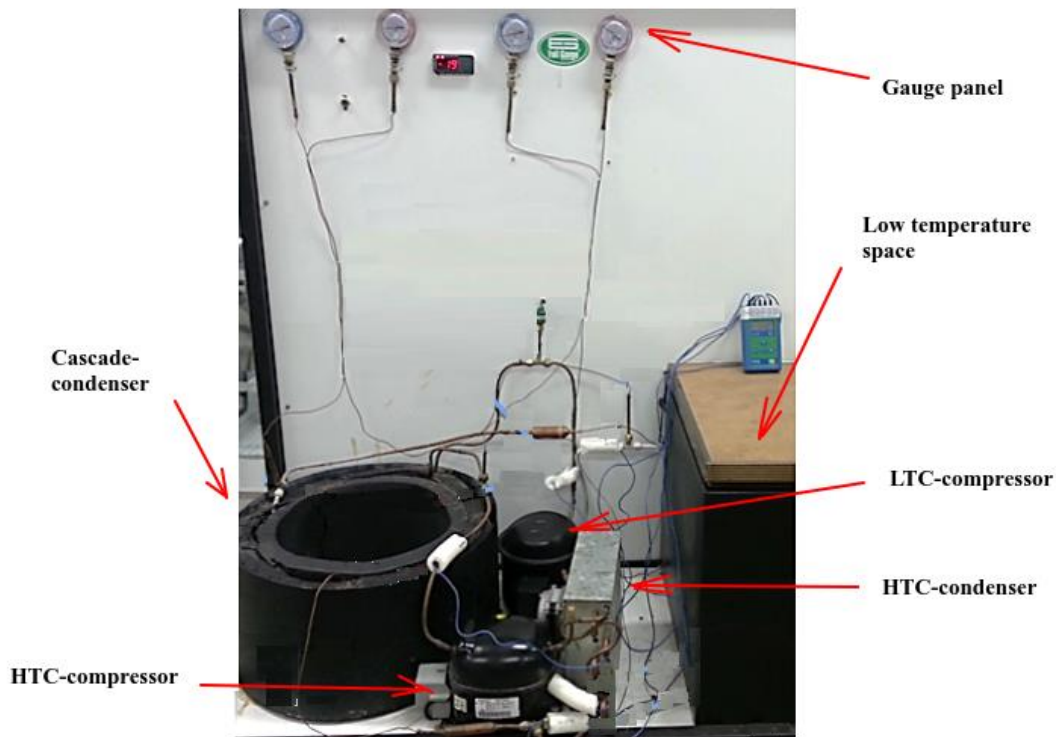

Figure 2. Assembly details of the cascade refrigeration prototype.

Suction, discharge and condensing pipe temperatures of the cascade LTC and HTC were collected by NTC-type 4 mm diameter sensors inserted into intrusive pockets, reducing measurement uncertainty. Ambient and refrigerated space temperature were measured during the tests. A data acquisition system allowed real-time data acquisition. A non-intrusive volumetric flowmeter manufactured by Vectus®, model TUSM-2000 (uncertainty $\pm 2\%$) was used to measure the volumetric



RECIMA21 - REVISTA CIENTÍFICA MULTIDISCIPLINAR ISSN 2675-6218

EXPERIMENTAL EVALUATION OF A CASCADE REFRIGERATION SYSTEM USING R-134a AND R-404a
Vitor Pinheiro Ferreira, Micael Lima Conceição, William Souza dos Santos

flow of HTC refrigerant and thus determine HTC mass flow rate. The total power supplied to the cascade refrigeration system was obtained using a digital wattmeter (resolution of 0.1 W) with a sampling frequency of 3 Hz.

Thermodynamic Assumptions

The system was modeled incorporating each process individually. For the energy analysis, some assumptions were made:

- The system operates at steady state;
- The kinetic and potential energy effects were not taken into account;
- Heat transfer in cascade-condenser with the ambient is negligible;
- The expansion process is isenthalpic;
- Pressure drop in the pipes and heat exchangers are negligible.

Based on these assumptions, the mass and energy balances in each process of two cycles can be established (MORAN; SHAPIRO, 2009), as described in Table 2, where \dot{V}_H is the volumetric flow rate of HTC refrigerant measured during the tests.

Since the only useful refrigerating effect is produced in the evaporator of low temperature cascade system, COP can be determined by ratio of LTC evaporator heat and work done. In addition to the COP of each cycle (see equations 1 and 2), the global COP was determined (see equation 3). Finally, EER (Energy Efficiency Ratio) was determined by Equation 4.

Table 2. Balance equations for each system component.

Component	LTC	HTC
Compressor	$\dot{m}_1 = \dot{m}_2 = \dot{m}_L$	$\dot{m}_5 = \dot{m}_6 = \dot{m}_H = \frac{\dot{V}_H}{v}$
	$\dot{W}_L = \dot{m}_L \cdot (h_2 - h_1)$	$\dot{W}_H = \dot{m}_H \cdot (h_6 - h_5)$
Condenser	$\dot{m}_3 = \dot{m}_2 = \dot{m}_L$	$\dot{m}_7 = \dot{m}_6 = \dot{m}_H$
	$\dot{Q}_{cond_L} = \dot{m}_L \cdot (h_2 - h_3)$ $= \dot{Q}_{evap_H}$	$\dot{Q}_{cond_H} = \dot{m}_H \cdot (h_6 - h_7)$
Expansion device	$h_3 = h_4$	$h_7 = h_8$
Evaporator	$\dot{m}_4 = \dot{m}_1 = \dot{m}_L$	$\dot{m}_8 = \dot{m}_5 = \dot{m}_H$
	$\dot{Q}_{evap_L} = \dot{m}_L \cdot (h_1 - h_4)$	$\dot{Q}_{evap_H} = \dot{m}_H \cdot (h_5 - h_8)$ $= \dot{Q}_{cond_L}$

$$COP_L = \frac{h_1 - h_4}{h_2 - h_1} \tag{1}$$

$$COP_L = \frac{h_5 - h_8}{h_6 - h_5} \tag{2}$$

$$COP = \frac{\dot{Q}_{evap_L}}{\dot{W}_L + \dot{W}_H} = \frac{\dot{m}_L \cdot (h_1 - h_4)}{\dot{m}_L \cdot (h_2 - h_1) + \dot{m}_H \cdot (h_6 - h_5)} \tag{3}$$

$$EER = \frac{\dot{Q}_{evap_L}}{\dot{E}} = \frac{\dot{m}_L \cdot (h_1 - h_4)}{\dot{E}} \tag{4}$$

Where: \dot{E} is the total energy rate consumed by the system.

Experimental Procedure

Experiments evaluated the performance of a cascade refrigeration system using R-134a/R-404a refrigerants under five different LTC evaporating temperatures. These conditions were obtained by varying the thermal load by using heaters positioned inside the low temperature space. During

prototype start up, HTC was the first cycle to be initialized. LCT was only turned on when the HTC evaporating temperature was at least -5 °C, thus avoiding overloading of the LTC compressor due to high discharge pressure. An automatic pressure switch was installed at the LTC discharge pipe as a safety device. Tests were conducted under constant conditions of HTC condensing medium. The ambient temperature and humidity were 29 ± 2 °C and $60 \pm 3\%$. Performance results for LTC evaporating temperature from -15 to -35 °C are shown in the next section.

RESULTS AND DISCUSSION

HTC condensing temperature showed little significant variations at all LTC evaporating conditions tested, remaining in 43 ± 1 °C. Figure 3 shows the variation of saturation conditions at the cascade-condenser. As LTC evaporating temperature increases, the compressor mass flow rate for this cycle increases, thus increasing the heat rejected by this cycle at the cascade-condenser and increasing the LTC condensing temperature. However as this exchanger was designed to operate at an LTC evaporating temperature of -40°C, the limited exchange area restricted the heat exchange between LTC and HTC refrigerants in another conditions, leading to an increase in the temperature differential in the cascade-condenser as LTC evaporating temperature was increased.

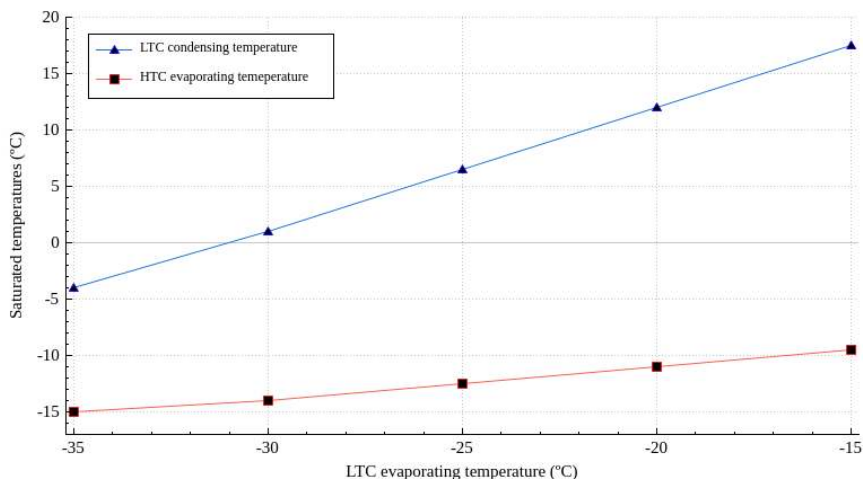

Figure 3. Saturation conditions in the cascade-condenser.

LTC input energy flows are shown in figure 4. As the evaporating temperature control strategy for this cycle was to increase the heat supplied into the low temperature space, an increase in the heat absorbed by the evaporator in this cycle was expected. The compression work done shows a slight increase as evaporating temperature rises. This occurred due to the increase in the compressor discharge pressure of this cycle, given that the LTC condensing temperature increased significantly, as shown previously in Figure 3, which provided an increase in the compression rate of this cycle and therefore an increase in the power consumed by LTC compressor.



RECIMA21 - REVISTA CIENTÍFICA MULTIDISCIPLINAR ISSN 2675-6218

EXPERIMENTAL EVALUATION OF A CASCADE REFRIGERATION SYSTEM USING R-134a AND R-404a
Vitor Pinheiro Ferreira, Micael Lima Conceição, William Souza dos Santos

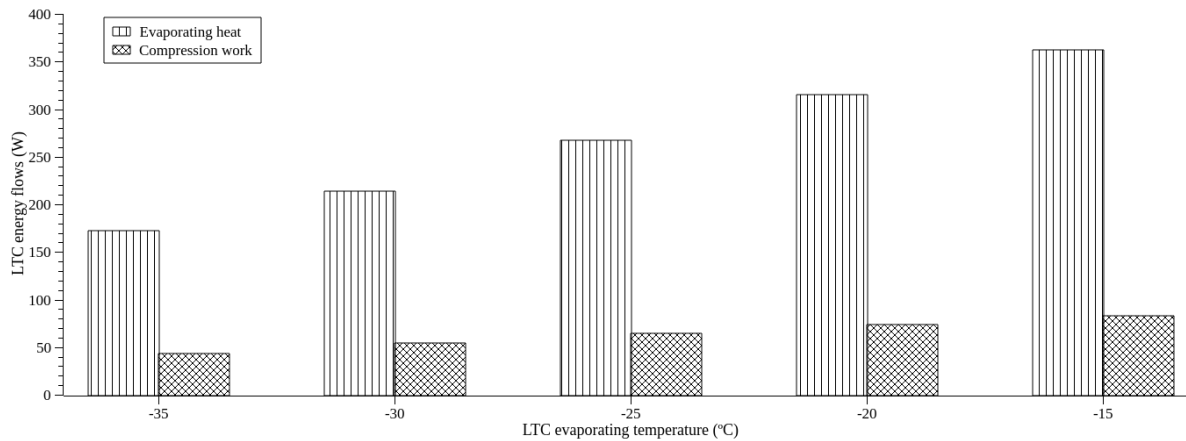

Figure 4. LTC input energy flows.

The HTC input energy flows are shown in figure 5. The increase in the LTC evaporating temperature of the LTC cycle leads to a higher rate of rejected heat in the cascade-condenser, which provides an increase in the evaporating heat absorbed by the cascade HTC. As the variation in the discharge pressure of this cycle was not significant, the increase in the suction pressure of this cycle due to the increase in the HTC evaporating temperature as the LTC evaporating temperature increased (see figure 3) caused a small reduction on the compression ratio of this cycle, which reduces the compression work done by cascade HTC. Furthermore as discussed by Sun et al., (2016), as the HTC compression ratio decreases, isentropic compressor efficiency is also increased, leading to a smaller enthalpy variation in the compression process and, therefore, less power consumed.

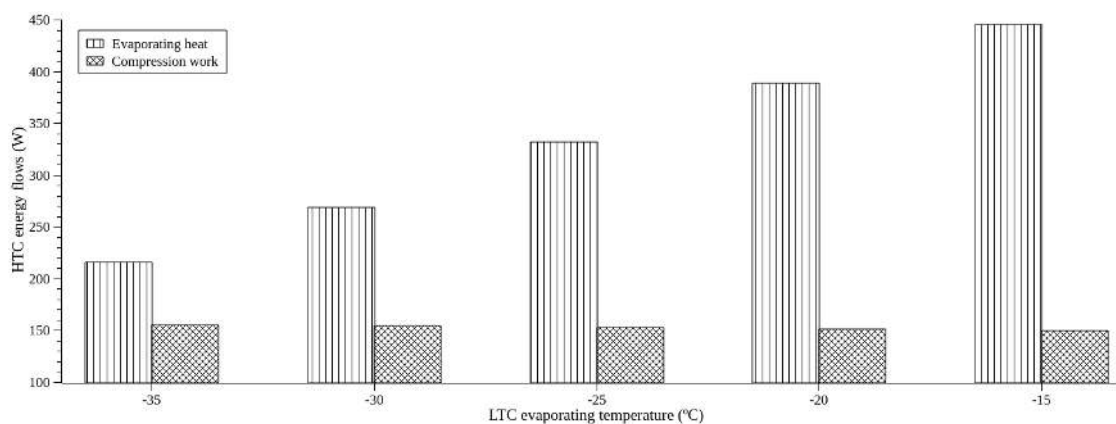

Figure 5. HTC input energy flows.

Figure 6 shows the variation of the coefficient of performance for each cycle (HTC and LTC). The increase in heat absorbed in the evaporator and a simultaneous reduction of the HTC compression



RECIMA21 - REVISTA CIENTÍFICA MULTIDISCIPLINAR ISSN 2675-6218

EXPERIMENTAL EVALUATION OF A CASCADE REFRIGERATION SYSTEM USING R-134a AND R-404a
Vitor Pinheiro Ferreira, Micael Lima Conceição, William Souza dos Santos

work, provided a significant increase in COP of this cycle with the increase in LTC evaporating temperature. An increase in COP of cascade LTC is less accentuated since the increase in the heat absorbed by evaporator is accompanied by a slight increase in the compression work done, which reduces the COP growth rate with the increase in LTC evaporating temperature.

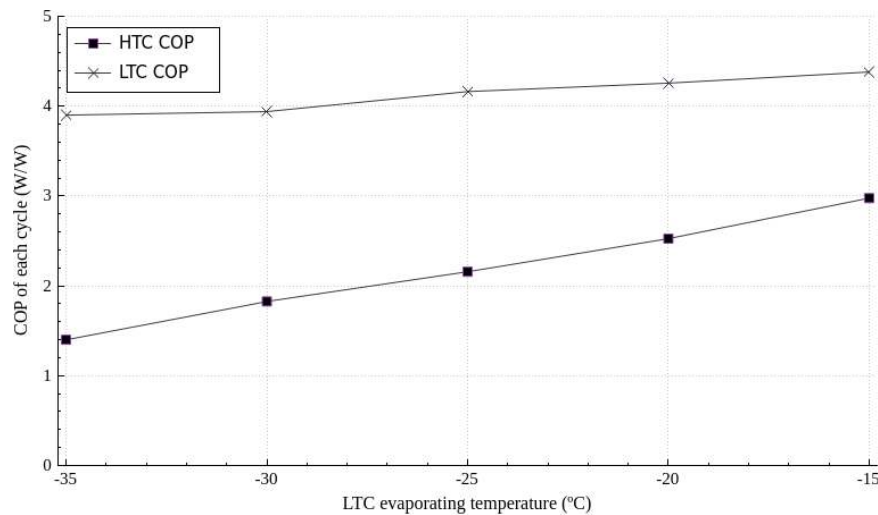

Figure 6. Coefficient of Performance of each cycle.

Since the COP of each cycle increased with the increase in LTC evaporating temperature, the global COP of the system was increased, as illustrated in figure 7. Bellos and Tzivanidis (2019) found similar results when simulated several refrigerants in a thermodynamic model of cascade refrigeration system.

A better heat exchange in the condenser-cascade could reduce the saturated temperature difference under high LTC evaporating temperatures and thus improve the overall performance of the system, as discussed by Getu and Basal (2008) who, analyzed the effect of temperature difference in cascade-condenser on the global COP of a cascade refrigeration system.

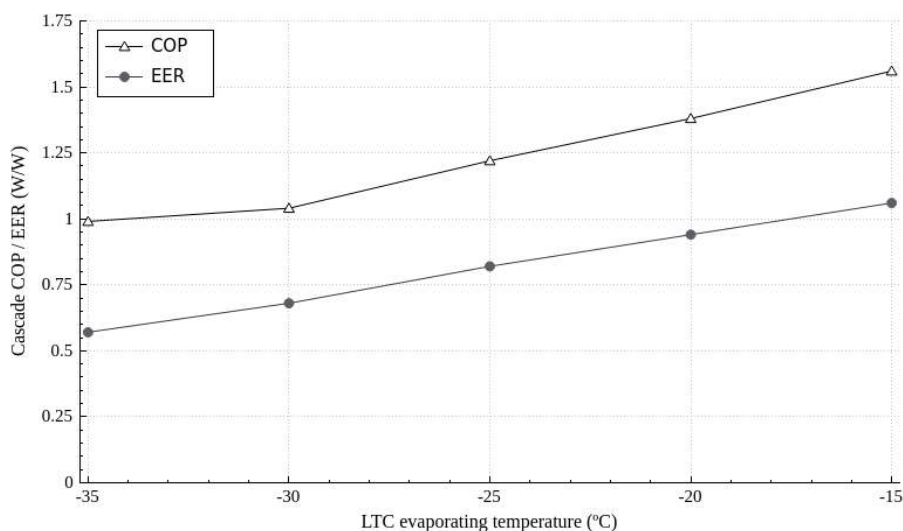

Figure 7. Cascade Coefficient of Performance and EER.

EER (Energy Efficiency Ratio) is a parameter that relates the useful heat absorbed by refrigeration system's evaporator with the total energy consumed by the machine, including the power needed to supply fans, pumps and other accessories. As shown in Figure 7, this parameter behaves similarly to that observed for COP, however with smaller absolute values those verified for COP. It occurs because, in EER calculation, the powers consumed by the fans and other accessories were effectively taken into account in order to determine the total consumed energy, reducing the ratio between useful and consumed energy.

CONCLUSIONS

This work showed an experimental performance analysis of a cascade refrigeration system operating with R-134a as refrigerant in the high temperature cycle and R-404a in the low temperature cycle.

In general, the increase in the LTC evaporating temperature provided an increase in the LTC condensing temperature of the LTC cycle, in addition to an increase in the temperature differential between the refrigerants in the cascade-condenser due to the restricted heat exchange imposed by the design conditions of this heat exchanger.

COP of both cycles increased with the LTC evaporating temperature, especially for HTC due to reduction of compression ratio. The global COP of the cascade system also increased with increase in LTC evaporating temperature, even with a simultaneous increase of temperature difference in cascade-condenser.

Global EER (Energy Efficiency Ratio) of the cascade system showed a similar behavior to that observed for COP, however with lower absolute values than those verified for COP.

**ACKNOWLEDGEMENTS**

The authors thank the FullGauge® for the thermal sensors and data acquisition system donation.

REFERENCES

- ALHAMID, M. Idrus; SYAKA, Darwin R. B; NASRUDDIN. Exergy and Energy Analysis of a Cascade Refrigeration System Using R744+R170 for Low Temperature Applications. **International Journal of Mechanical & Mechatronics Engineering IJMME-IJENS**, v. 10, n. 06, 2010.
- BELLOS, Evangelos; TZIVANIDI, Christos. A Theoretical Comparative Study of CO₂ Cascade Refrigeration Systems. **Appl. Sci.**, v. 9, n. 4, p. 790, 2019. doi:10.3390/app9040790
- BINGMING, Wang; HUAGEN, Wu; JIANFENG, Li; ZIWEN, Xing. Experimental Investigation on the Performance of NH₃/CO₂ Cascade Refrigeration System with Twin-Screw Compressor. **International Journal of Refrigeration**, v. 32, p.1358–1365, 2009. doi: 10.1016/j.enconman.2010.06.037.
- COLORADO, D.; RIVERA, W. Performance Comparison Between a Conventional Vapor Compression and Compression-Absorption Single-Stage and Double-Stage Systems Used for Refrigeration. **Applied Thermal Engineering**, 2015. doi: 10.1016/j.applthermaleng.2015.05.029.
- DOKANDARI, Damoon Aghazadeh; HAGH, Alireza Setayesh; MAHMOUDI, S. M. S. Thermodynamic Investigation and Optimization of Novel Ejector-Expansion CO₂ /NH₃ Cascade Refrigeration Cycles (novel CO₂/NH₃ cycle). **International Journal of Refrigeration**, v. 46, p. 26-36, 2014. doi:10.1016/j.ijrefrig.2014.07.012
- DOPAZO, J. Alberto Dopazo; SEARA, José Fernández-Seara; UHIA, Jaime Sieres, Francisco J. Theoretical analysis of a CO₂-NH₃ cascade refrigeration system for cooling applications at low temperatures. **Applied Thermal Engineering**, v. 29, p. 1577–1583, 2009.
- DOPAZO, J. Alberto; FERNÁNDEZ-SEARA, José. Experimental Evaluation of a Cascade Refrigeration System Prototype with CO₂ and NH₃ for Freezing Process Applications. **International Journal of Refrigeration**, v. 34, p. 257-267, 2011. doi: 10.1016/j.ijrefrig.2010.07.010.
- DU, Kai Du; ZHANG, Shaoqian; XU, Weirong; NIU, Xiaofeng. A Study on the Cycle Characteristics of an Auto-Cascade Refrigeration System. **Experimental Thermal and Fluid Science**, v. 33, p. 240–245, 2009. doi: 10.1016/j.exptthermflusci.2008.08.006.
- GETU, H. M.; BANSAL, P. K. Thermodynamic Analysis of an R744–R717 Cascade Refrigeration System. **International Journal of Refrigeration**, v. 31, 45–54, 2008. doi:10.1016/j.ijrefrig.2007.06.014.
- KILICARSLAN, A.; HOSOZ, M. Energy And Irreversibility Analysis of a Cascade Refrigeration System for Various Refrigerant Couples. **Energy Conversion and Management**, v. 51, p. 2947–2954, 2010. doi: 10.1016/j.enconman.2010.06.037.
- LEE, Tzong-Shing; LIU, Cheng-Hao; CHEN, Tung-Wei. Thermodynamic Analysis of Optimal Condensing Temperature of Cascade-condenser in CO₂ /NH₃ Cascade Refrigeration Systems. **International Journal of Refrigeration**, v. 29, p. 1100-1108, 2006. doi: 10.1016/j.ijrefrig.2006.03.003.
- MESSINEO, Antonio. Cascade Refrigeration System: Performance Evaluation Compared with a HFC Two-Stage System. **Energy Procedia**, v. 14, p. 56–65, R744-R717, 2012.



RECIMA21 - REVISTA CIENTÍFICA MULTIDISCIPLINAR ISSN 2675-6218

EXPERIMENTAL EVALUATION OF A CASCADE REFRIGERATION SYSTEM USING R-134a AND R-404a
Vitor Pinheiro Ferreira, Micael Lima Conceição, William Souza dos Santos

MORAN, M. J.; SHAPIRO, H. N. **Princípios da Termodinâmica**. 6. ed. São Paulo: LTC, 2009.

MUMANACHIT, P.; REINDL, D. T.; NELLIS, G. F. Comparative analysis of low temperature Industrial Refrigeration Systems. **International Journal of Refrigeration**, v. 35, p. 1208-1221, 2012. doi: 10.1016/j.ijrefrig.2012.02.009.

PAN, Mingzhang; ZHAO, Huan; LIANG, Dongwu; ZHU, Yan; LIANG, Youcai; BAO, Guangrui. A Review of the Cascade Refrigeration System. **Energies**, v. 13, 2254, 2020. doi:10.3390/en13092254.

PAREKH, A. D. Parekh; TAILOR, P. R. Thermodynamic Analysis of R507A-R23 Cascade Refrigeration System. **World Academy of Science, Engineering and Technology**, v. 57, 2011. doi:10.1016/j.ijrefrig.2007.06.014.

SILVA, Alessandro da; FILHO, Enio Pedone Bandarra; ANTUNES, Arthur Heleno Pontes. Comparison of a R744 Cascade Refrigeration System with R404a and R22 Conventional Systems for Supermarkets. **Applied Thermal Engineering**, v. 41, p. 30e35, 2012. doi:10.1016/j.applthermaleng.2011.12.019.

SUN, Zhili; LIANG, Youcai; LIU, Shengchun; JI, Weichuan; ZANG, Runqing; LIANG, Rongzhen; GUO, Zhikai. Comparative Analysis of Thermodynamic Performance of a Cascade Refrigeration System for Refrigerant Couples R41/R404a and R23/R404a. **Applied Energy**, v. 184, p. 19–25, 2016. doi:10.1016/j.apenergy.2016.10.014.

YOON, Jung-In; CHOI, Won-Jae; LEE, Sanggyu; CHOE, Kunhyung; SHIM, Gyu-Jin. Efficiency of Cascade Refrigeration Cycle Using C₃H₈, N₂O, and N₂. **Heat Transfer Engineering**, v. 34, p. 959-965, 2013. doi:10.1080/01457632.2012.753575.

NOMENCLATURE

COP	Coefficient of performance
EER	Energy efficiency ratio
\dot{E}	Electric energy consumed by the system
GWP	Global warming potential
h	enthalpy
HTC	High temperature cycle
LMTD	Log mean temperature difference
LTC	Low temperature cycle
\dot{m}	Mass flow
NTC	Negative temperature coefficient sensor
ODP	Ozone depletion potential
v	Specific volume
\dot{V}	Volumetric flow rate
\dot{W}	Compression work done
\dot{Q}	Heat flow rate